

MXL, MXL-IQ and MXLV Panels

Intelligent *FirePrint*[™] Detector Model FP-11

ARCHITECT AND ENGINEER SPECIFICATIONS

- Most Sophisticated "Detector Intelligence" available in the Fire / Life Safety market
- Multi-criteria fire detection for the price of a photoelectric detector
- *FirePrint*[™] technology to distinguish between deceptive phenomena and an actual fire
- Easily programmed to match specific hazard profiles from the fire-alarm control panel (FACP)
- *Pre-Alarm* reporting based upon fire profile selected
- Remote-sensitivity-measurement capability
- System-logic activation based upon any of three (3) inputs from the detector (smoke, heat or neural network)
- Field-cleanable chamber with replaceable chamber parts
- Compatible with field programmer / tester (Model DPU) or FPI-32 Upgrade Kit
- Supports software-based, automatic environmental compensation (EnviroLINK)
- Backward compatible with older MXL systems (Rev. 2 and above)
- Optional fully programmable relay base, audible base and duct housing



- Multi-color, detector-status LED
- (2) Two-wire operation
- [®]UL and [®]ULC Listed; FM, CSFM & NYMEA Approved

Product Overview

The Intelligent Fire Detector (Model FP-11) provides the most highly evolved detection system – including the most sophisticated level of protection; as well as nuisance-alarm immunity – currently available in the Fire / Life Safety market.

Model FP-11 utilizes advanced detection technology that allows the detector to distinguish non-threatening deceptive phenomena (i.e. - cigarette smoke) from actual fire hazards, while optimizing detection for the area of its intended zone. Model FP-11 uses state-of-the-art microprocessor circuitry with error check, detector self-diagnostics and supervision programs.

Model FP-11 is compatible with the Siemens Industry, Inc. – Fire Safety division's FPI-32 upgrade kit or Siemens' field-programmer / tester (Model DPU), which is a compact, portable and menu-driven accessory for efficiently programming and testing detectors electronically. Model DPU or FPI-32 upgrade kit eliminates the need for cumbersome, unreliable mechanical programming

methods and reduces installation and service costs by electronically programming and testing the detector prior to installation.

Specifications

Model FP-11 is a plug-in, two-wire, multi-sensor detector with photoelectric and thermal inputs that is compatible with the MXL family of FACPs. Each detector consists of a dust-resistant, field-cleanable photo chamber; a solid-state, non-mechanical thermal sensor, and microprocessor-based electronics with a low-profile plastic cover and base.

Model FP-11 utilizes state-of-the-art ASIC and surface-mount technology for maximum reliability. Every Model FP-11 fire detector is shipped with a protective dust cover. Model FP-11 fire detector utilizes an infrared light-emitting diode (IRLED), and light sensing photodiode. Under normal conditions, light transmitted by the LED is directed away from the photodiode and scattered through the smoke chamber in a controlled pattern.

Intelligent *FirePrint*[™] Detector **6175**

Specifications – (continued)

The smoke chamber is designed to manage light dissipation and extraneous reflections from dust particles or other non-smoke airborne contaminants in such a way as to maintain stable, consistent detector operation. When smoke enters the detector chamber, light emitted from the IRLED is scattered by the smoke particles, and is received by the photodiode.

Model FP-11 also utilizes a modern, accurate and shock-resistant thermistor to sense temperature changes. The 'on-board' *FirePrint* technology allows the detector to gather smoke and thermal data, analyzing this data in the detector's 'neural network.' By comparing data received with the common characteristics of fires, or fire fingerprints, Model FP-11 can compare these 'fire prints' to those of deceptive phenomena that cause other detectors to alarm. The advanced *FirePrint* technology allows the Model FP-11 to accurately determine a true fire hazard from non-threatening, deceptive phenomena – without the need to use alarm delaying verification and confirmation techniques, which can increase the probability of losses due to fire.

Model FP-11 provides the highest level of detector intelligence available today with a detector / control-panel link that allows the user to program the detector for the specific hazard profile. Detectors are optimized by selecting one (1) of the following applications:

- Office / Retail
- Lobby
- Computer room
- Dormitory
- Healthcare facility
- Parking garage
- Utility / transformer room
- Hostile environment
- Precious storage
- Air duct
- Warehouse / light manufacturing

Once programmed, the software does the rest – no guessing on detector sensitivities or alarm verification – the FACP programs Model FP-11 for the protected area without any confirmation delays. Once optimized for the hazards in the protected area, Model FP-11 provides the utmost means in detection. Should the operator or installer forget to program the detector, Model FP-11 will revert to a default setting that, in turn, allows operation as a standard photoelectric or photothermal detector.

The FP-11's *FirePrint* technology for Model FP-11 monitors input from the photo chamber and the thermal sensor, evaluating this information with

sophisticated mathematical formulas or algorithms – comparing this input to characteristics of both threatening fires and deceptive phenomena that would deceive any ordinary detector. This technology was developed over years of research and reviewing the results of over 20 years of fire-test data in one of the world's most advanced fire research centers. The results of this research are the mathematical models that form the algorithms used in *FirePrint*. No other fire detector has this level of intelligence or this amount of research and development supporting its design.

The software of the microprocessor can identify and disregard false input caused by radio frequency (RFI) and electromagnetic (EMI) interference, and validates all *trouble* conditions before annunciating or reporting to the control panel. The microprocessor for Model FP-11 uses an integral EEPROM to store the detector's address and other critical operating parameters, which include the assigned program values for *alarm* and *trouble* thresholds.

Communications within the detector; between Model FP-11 and the FACP; or with the field programmer / tester (Model DPU), are supervised and safeguarded against disruption by reliable, microprocessor-based error checking routines. Additionally, the microprocessor supervises all EEPROM memory locations and provides a high degree of EEPROM failure fault tolerance.

In MXL / (V) applications, Model FP-11 determines its operating status to be in *normal*, *alarm*, or *trouble* mode, depending on the difference between the alarm threshold values stored in the detector's memory and the detector's latest analog measurement. The detector then communicates changes in its status to the FACP.

In addition, the MXL / (V) FACP will sample the value of the analog signal for Model FP-11 over a period of time, in order to determine if those values indicate excessive buildup in the photo chamber. In the event of excessive buildup, the MXL / (V) FACP will accurately indicate which detector shall require maintenance.

Model FP-11 is listed as a self-testing device. The LED for Model FP-11 flashes GREEN every four (4) seconds, indicating communication with the FACP, and that it has passed its self-test. Should the detector sense a fault or failure within its systems, the LED will flash AMBER, and the detector will transmit that data to the FACP. A quick visual inspection is sufficient to indicate the condition of the detector at any time. If more detailed information is required, a printed report can be provided from the MXL panel, indicating the status and settings assigned to each individual detector.

When Model FP-11 moves to the *alarm* mode, it will flash AMBER, and will transmit that data to the FACP. When the MXL / (V) confirms the condition of the detector, the FACP will instruct Model FP-11 to flash

Specifications — (continued)

RED – and to continue flashing RED, until the system is reset manually at the FACP. At that same time, any user-defined system alarm functions programmed into the system are activated. Each Model FP-11 detector can operate one (1) remote alarm indicator; one (1) auxiliary relay, or one (1) audible base.

Detector sensitivity, calibration and identification are dynamically supervised by the FACP. Detector sensitivity and *pre-alarm* levels are a function of the application chosen at the FACP, and are controlled by the panel. If an alternate, non-*FirePrint* mode is selected, then the sensitivity can be changed from the FACP.

The Program / Test unit (Model DPU) or FPI-32 upgrade kit is used to program and verify the detector's address. The technician selects the accessory's program mode to enter the desired address. In turn, Model DPU or FPI-32 automatically sets / verifies the address, and tests the detector. Model DPU also allows the user to change the device ID from that of a Model FP-11 detector to an older detector ID (such as: ILP-1, ILPT-1, ILP-2, ID-60P or ID-60PT) to allow for easy replacement of older detectors without the need of reprogramming the FACP.

The FPI-32 upgrade kit operates on AC power or rechargeable batteries, providing flexibility and convenience in programming and testing equipment from almost any location. When in test mode, Model DPU or FPI-32 upgrade kit will perform a series of diagnostic tests without altering the address or other stored data, allowing technicians to determine if the detector is operating properly.

Model FP-11 may be installed on the same initiating circuit with IL or ID series detectors (Photoelectric, thermal, or ionization), MSI-series manual stations, TRI-series interfaces, ICP output control devices, or CZM series of addressable, conventional-zone modules.

All Model FP-11 detectors can be cleaned in the field – when required – by simply removing the detector cover and unsnapping the photo chamber. There is also the option of cleaning the interior of the detector with a clean, soft cloth or brush, or replacing the labyrinth and bug screen included in the detector maintenance kit, Model DMK-11.

Model FP-11 uses the low-profile, surface-mounting base, Model DB-11. This base mounts on a 4-inch octagon, square, or a single-gang electrical box. The base utilizes screw-clamp contacts for electrical connections and self-wiping contacts for increased reliability. The base can be used with the optional Model LK-11 detector locking kit, which contains 50

detector locks, as well as an installation tool, preventing unauthorized removal of the detector head. Model DB-11 has integral, decorative plugs to cover the outer mounting screw holes.

Model FP-11 is electrically compatible with existing MXL-detector accessories, including relays, remote lamps, duct housings and audible bases. With duct housings, a base adapter and new detector housing cover are required (order AD-11UK upgrade kit). To use existing Model DB-3S base or audible base, Model FP-11 requires a base adapter (Model DB-ADPT).

All Model FP-11 detectors are approved for operation within the UL-specified temperature range of 32°F (0°C) to 100°F (38°C).

Application Data

Installation of the Model FP-11 series of fire detectors requires a (2) two-wire circuit of 18 AWG (minimum) thermoplastic fixture wire enclosed in conduit, or 18 AWG (American Wire Gauge) limited energy, shielded cable without conduit, if permitted by local codes. Field wiring should conform to local and national electric codes and the control panel wiring specifications.

“T-tapping” is permitted only for Style 4 (Class B) wiring.

Model FP-11 fire detectors can be applied within the maximum 30-foot center spacing (900 sq. ft. areas), as referenced in NFPA 72. This applications guideline is based upon ideal conditions – specifically – smooth ceiling surfaces, minimal air movement, and no physical obstructions between potential fire sources and the detector. Do not mount detectors in close proximity to ventilation or heating and air-conditioning outlets.

Exposed joints or beamed ceilings may also affect safe spacing limitations for detectors. Should questions arise regarding detector placement, observe National Fire Protection Association (NFPA) 72 guidelines.

Dimensions

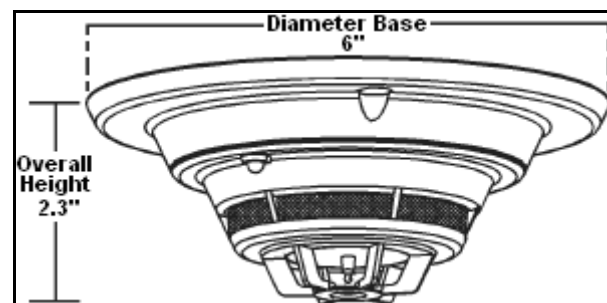

Technical Data

Environmental

Temperature: 32°F (0°C) to 100°F (38°C)
 Humidity: Up to 93% RH, non-condensing
 Air Pressure: No effect
 Alarm Temperature: 135°F (57°C)

Electrical

Voltage: 16-27 VDC
 Ripple: 3V peak-to-peak
 Supervisory Current: 110µA max
 Alarm Current: 33-50 mA

Details for Ordering

Model Number	Part Number	Description
FP-11	500-095112	Addressable <i>FirePrint</i> ™ Detector
DB-11	500-094151	Detector Mounting Base For Series 11 Intelligent Detectors
DB-11E	500-094151E	Detector Base (Small)
AD2-P	500-649706	Air-Duct Housing (for use with Models FP-11, HFP-11, HFPO-11 and PE-11 Detectors)
AD2-XHR	500-649708	Air-Duct Housing (for use with Models FP-11, HFP-11, HFPO-11 Detectors with Relay)
ADBX-11	500-096181	Audible Base
DB-X11RS	500-096125	Relay Base for Series 11 Intelligent Detectors
RLI-1	500-390673	Remote Alarm Indicator: 4" Octagon Box Mount, Red
RLI-2	500-390674	Remote Alarm Indicator: Single-Gang Mount, Red
DMK-11	500-695338	Series 11 Maintenance Kit (replacement labyrinth and bug screen)
DB-ADPT	500-094187	Base Adapter to Model DB-3S Base
LK-11	500-695350	Base Locking Kit for Series 11 Detectors

In Canada, please order:

Model Number	Part Number	Description
FP-11C	500-095112C	135°F Fixed Temperature, Plug-In Detector Addressable <i>FirePrint</i> ™ Detector [ULC Listed]
DB-11C	500-095687	Detector Mounting Base For Series 11 Intelligent Detectors [ULC Listed]
AD-11PC	500-095984	Air-Duct Housing [ULC Listed]
DB-X11RSC	500-093125C	Relay Base for Series 11 Intelligent Detectors [ULC Listed]
ADBX-11C	500-096181C	Audible Base for Series 11 Intelligent Detectors [ULC Listed]

Notice: This marketing catalog sheet is not intended to be used for system design or installation purposes. For the most up-to-date information, refer to each product's installation instructions.